

PRODUCT DATA SHEET

CLA-ECOBOOST3 + • 811045



BRAND



PRODUCT DETAILS

The EcoBoost3+ is a Self-Priming centrifugal jet pump with excellent suction capacity, even when air is present in the water.

With its compact sizing and a handy carry handle, EcoBoost3+ is portable and therefore suitable for emergency use such as drawing water from tanks or rivers. Equipped with an integrated pre-filter protecting the pump and making it easy to clean. A non-return valve is built into the pump body. The auto on/off controller with adjustable start pressure is plug and play making it easy to remove and replace.

APPLICATIONS

- Household water supply
- Gardening
- Drinking water

FEATURES

- Automatic On/Off
- Adjustable start pressure
- Built in non Return Valve
- Dry-Run Protection
- Inbuilt pressure gauge
- Easy to Use
- Thermal Protection

TECHNICAL DATA

RATED POWER (W)	1000
MAX. FLOW [LPM]	63
MAX. FLOW [M3/H]	3.7
MAX. HEAD [M]	43
MAXIMUM PRESSURE RATING	6 bar
MOTOR PROTECTION LEVEL	Class F
PROTECTION CLASS	IPX4
LIQUID TEMPERATURE	0°C-35°C
MAX. DIA. OF PARTICLE	2mm
MOTOR	Air Cooled
START PRESSURE	Default 2.2bar Adjustable 1.5 to 2.2. bar

RATED VOLTAGE	220V-240V 50Hz
RATED CURRENT	2.4A @ 230V
POWER CABLE TYPE	HS-05
LENGTH OF POWER CABLE	1.5m
IMPELLERS	1
MAXIMUM SUCTION DEPTH	5m
NON RETURN VALVE	Yes: Integrated
FILTER	Yes: Integrated, 1mm particles
SUCTION INLET	1" BSP F
CONTROLLER OUTLET	1" BSP F
PACKAGE DIMENSION	455x175x290mm
GROSS WEIGHT (KG)	9

CURVE

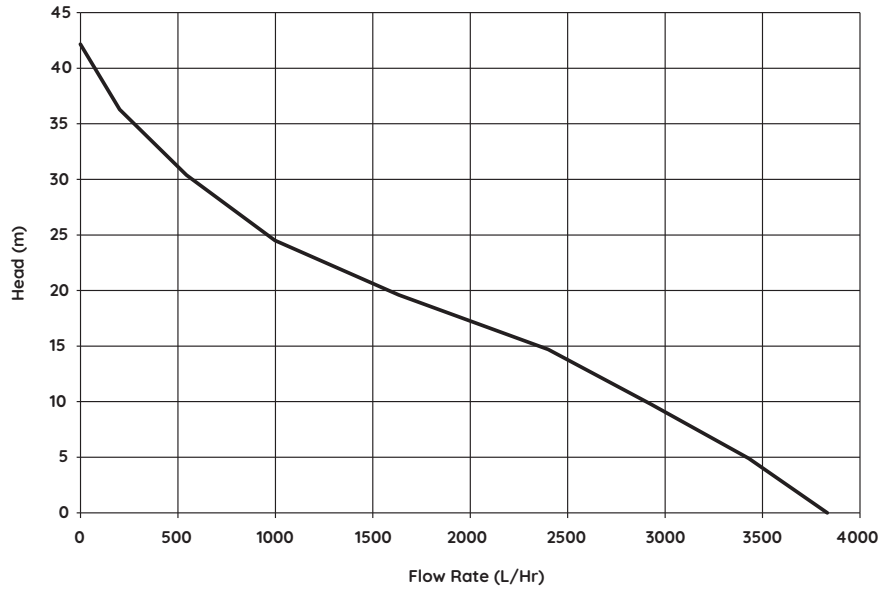

DIMENSIONS

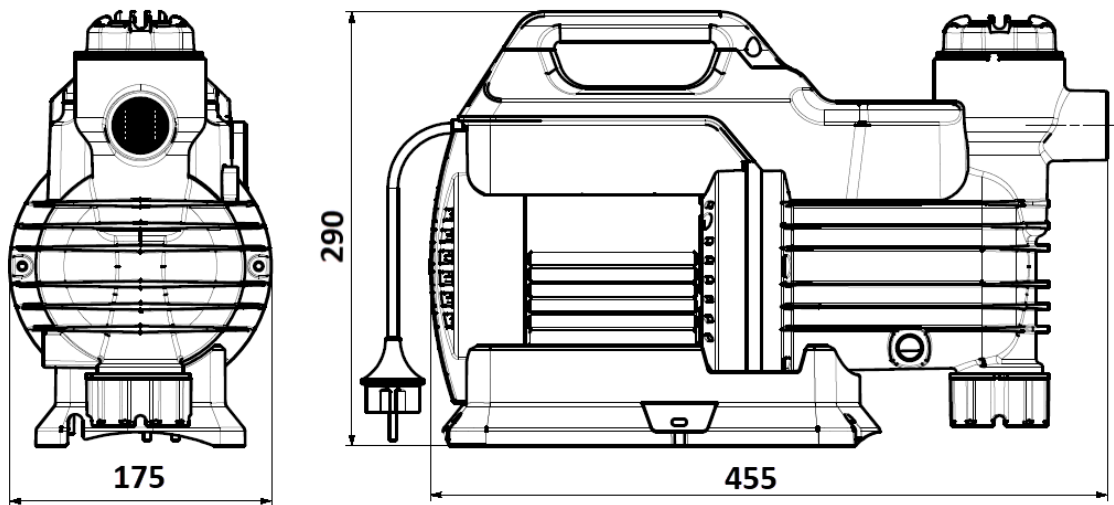

WARRANTY / CERTIFICATIONS

