

PASSAGE & PRIVACY LEVER SET INSTALLATION INSTRUCTIONS

IMPORTANT:

This Lever Set is designed to suit Left and Right opening doors. Please fasten all screws by hand. Do not use an electric screwdriver or drill as over tightening may impact the products function.

SAFETY TIP:



When assembling or installing this product wear protective gloves and eyewear.

STEP 1

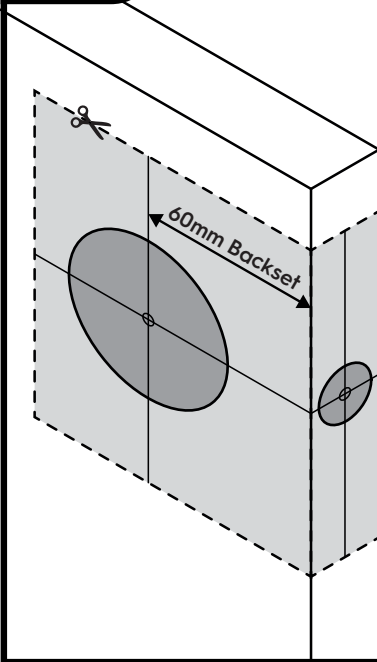

Cut out the "Drilling Template" printed on the rear. Fold the template around the edge of your door on the fold line at your desired height.

Mark the centre of the 2 holes needing to be drilled:

- 1x 54mm hole through the door surface
- 1x 25mm hole on the doors edge.

Once marked, you can now drill the holes. For the best finish drill the 54mm hole with a hole saw and the 25mm hole with a spade bit.

STEP 2

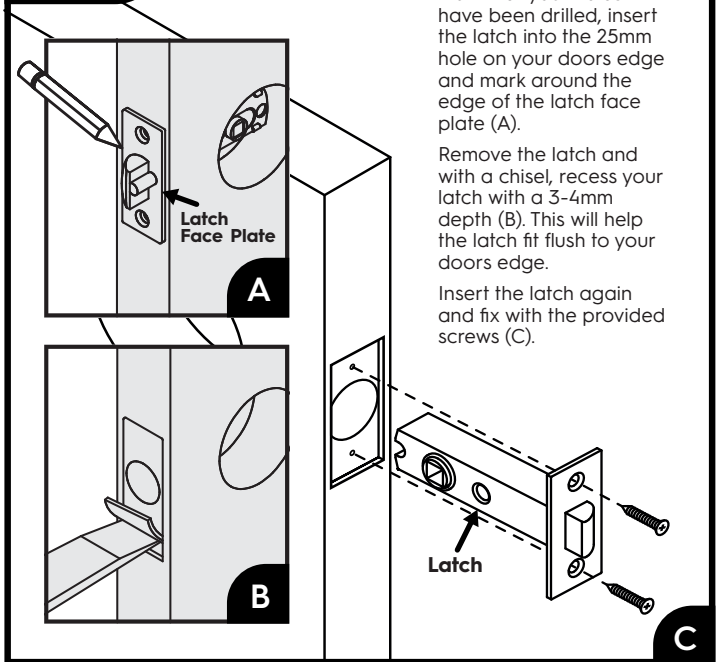

Now that your holes have been drilled, insert the latch into the 25mm hole on your doors edge and mark around the edge of the latch face plate (A).

Remove the latch and with a chisel, recess your latch with a 3-4mm depth (B). This will help the latch fit flush to your doors edge.

Insert the latch again and fix with the provided screws (C).

STEP 3

Once the latch is fixed in place, insert the spindle through the latch. Position the two sides of the lever ensuring they engage the spindle and fix with the provided screws. Now position the rose plate by sliding over the lever and firmly pushing until it is flush with the door surface.

Please note: "STEP 3a" Is only for Privacy function lever sets.

If installing a privacy lever set, ensure the side with the locking snib is positioned on the correct side of your door. Once the rose plate is in position, screw the locking snib in place and test.

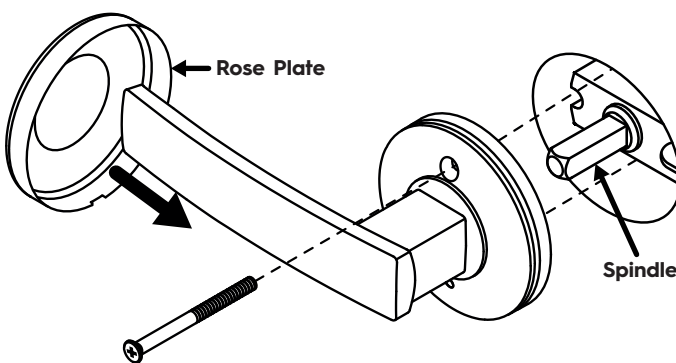

Use the below screw length based off your door thickness:

Between 32-38mm use:

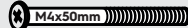

Between 39-45mm use:

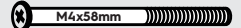

STEP 3a

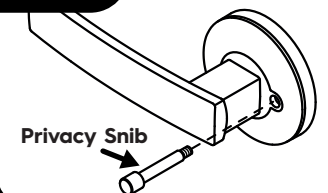

SCAN
FOR
INSTALLATION
VIDEO

STEP 4

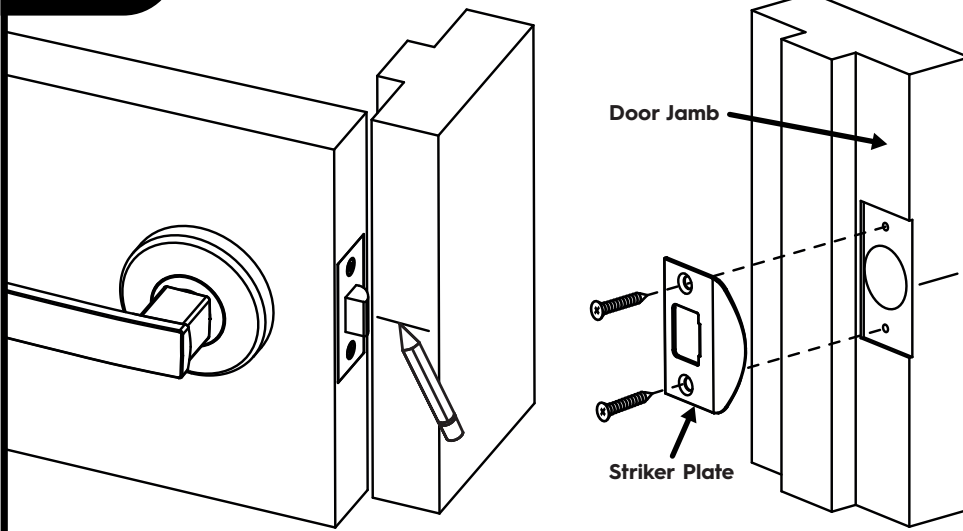

To install the striker plate, gently close the door until the latch bolt rests on the door jamb and mark the centre of the latch bolt. This mark will represent where the middle of your striker plate should be positioned.

Transfer the mark to the inside of your door jamb and drill a 25mm hole to a 12mm depth.

Position the striker plate in to the centre of the hole and mark around the edge of this plate to recess as per the latch in "STEP 2".

Once the striker plate is recessed into your door jamb, fix with the provided screws.

DRILLING TEMPLATE



Mark the centre of your door edge and drill a 25mm hole with a spade bit.

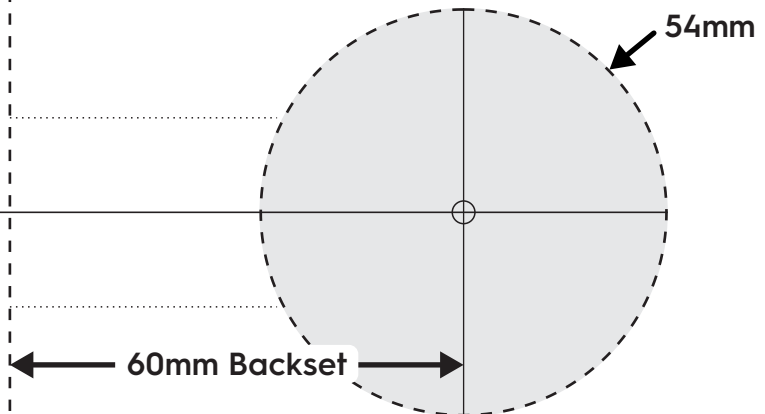

Fold on the dotted line and wrap around your doors edge at the desired height

SCALE TOOL

IF PRINTING AT HOME: Please measure the table to the right with a ruler to make sure this template is 100% scaled. If the measurement guide is not accurate, do not use this template to drill into your door.

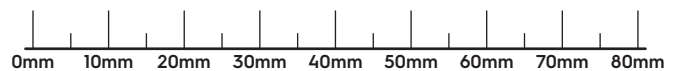

Delf Design Pty. Ltd provides a lifetime warranty. The warranty covers manufacturer defects in materials, workmanship and finish under normal use. This warranty is provided in addition to other rights and remedies you may have under law. Our goods come with guarantees that cannot be excluded under the Australian consumer law or Consumer Guarantees Act 1993 (NZ). You are entitled to a replacement or refund for a major failure and compensation for any other reasonably foreseeable loss or damage. You are also entitled to have the goods repaired or replaced if the goods fail to be of acceptable quality and the failure does not amount to a major failure. This warranty excludes damage resulting from product misuse or product neglect, any modifications, additions or alterations to the product. To make a claim under this warranty, take the product (with proof of purchase) to any Bunnings store (for AUS customers see www.bunnings.com.au and for NZ customers see www.bunnings.co.nz for store locations). Delf bears reasonable, direct expenses of claiming under the warranty. You may submit details and proof of purchase to our support centre for consideration. This warranty is given by Delf. ABN 37 668 272 213, 45-49 Whitfield Boulevard, Cranbourne West Vic 3977, 1800 349 776, Email: support@delfarchitectural.com.au. 'Delf' is a trademark. © Delf Design Pty Ltd. Version control: DELDLI-25-02-25.