

AEG

AEGLDM50M

Original instructions

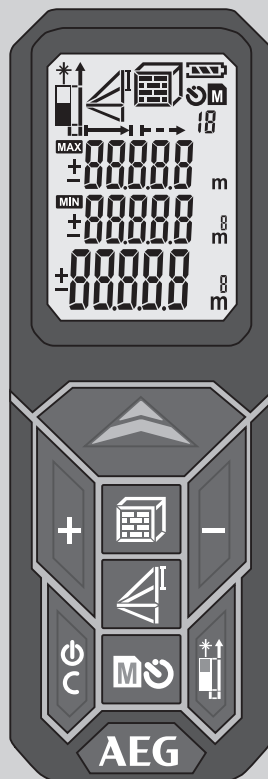

CONTENTS

Important safety instructions	1
Specified Conditions of Use	2
Error Code Table	2
Overview	3
Change batteries	4
Corner Pin.....	4
Belt Clip.....	4
Function Switch, Pythagoras, Measuring Reference	5
Single Distance Measuring	6
Permanent / Minimum-Maximum Measuring.....	7
Add / Subtract Measuring.....	8
Area Measuring	9
Volume Measuring.....	10
Indirect Measuring (Pythagoras 1).....	11
Indirect Measuring (Pythagoras 2).....	12
Indirect Measuring (Pythagoras 3).....	13
Wall Area Measuring (Scenario 1).....	14
Wall Area Measuring (Scenario 2).....	15
Timer	16
Memory	16
Basic Description on example of Area measuring (1).....	17
Basic Description on example of Area measuring (2).....	18

IMPORTANT SAFETY INSTRUCTIONS

Laser Classification

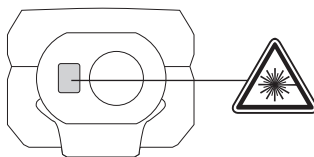

WARNING:
It is a Class 2 laser product in accordance with **AS/NZS IEC 60825.1:2014**



WARNING:
Avoid direct eye exposure. The laser beam can cause flash blindness.

Do not stare into the laser beam or direct it towards other people unnecessarily.

Don't dazzle other individuals.

WARNING:
Do not operate the tool around children or allow children to operate the tool.

SYMBOLS



Safety alert



Regulatory Compliance Mark (RCM). Product meets applicable regulatory requirements.



Please read the instructions carefully before starting the machine.



Do not dispose of electric tools together with household waste material. Electric tools and electronic equipment that have reached the end of their life must be collected separately and returned to an environmentally compatible recycling facility.

LASER DISTANCE MEASURER SAFETY WARNINGS

The reflective surface could reflect the beam back at the operator or other persons.

Keep extremities in a safe distance from the moving parts. Carry out periodic test measurements. Particularly before, during and after important measurements.

Watch out for erroneous measurements if the product is defective or if it has been dropped or has been misused or modified.

WARNING: Use of controls, adjustments, or the performance of procedures other than those specified in the manual may result in hazardous radiation exposure.

The laser distance measurer has limits of use. (Refer to the "Technical data" section). Attempts to measure outside the maximum and minimum range will cause inaccuracy. Use in adverse conditions including too hot, too cold, very bright sunlight, rain, snow, fog, or other vision restricting conditions will result in inaccurate readings.

When the laser distance measurer is brought into a warm environment from very cold conditions, or vice versa, allow it to come to the surrounding temperature before use.

Always store the laser distance measurer indoors, avoid exposing the tool to shock, continuous vibration or extreme temperatures.

Always keep the tool away from dust, liquids and high humidity. These may damage internal components or affect accuracy.

Do not use aggressive cleaning agents or solutions. Use only a clean, soft cloth for cleaning.

Avoid heavy impact to or dropping of the measuring tool. The accuracy of the tool should be checked before use if it has been dropped or subjected to other mechanical stresses.

Any repair required on this laser product should be performed only by authorised service personnel.

Do not operate the product in explosion hazardous areas or in aggressive environments.



Flat batteries must not be disposed of with household waste. Care for the environment and take them to the collection points provided in accordance with national or local regulations. The product must not be disposed with household waste. Dispose of the product appropriately in accordance with the national regulations in force in your country. Adhere to the national and country specific regulations. Please contact your local authority or your dealer for how to dispose of batteries properly.

ADDITIONAL BATTERY SAFETY WARNINGS

WARNING: To reduce the risk of fire, personal injury, and product damage due to a short circuit, never immerse your tool, battery pack or charger in fluid or allow a fluid to flow inside them. Corrosive or conductive fluids, such as seawater, certain industrial chemicals, and bleach or bleach-containing products, etc., can cause a short circuit.

TECHNICAL DATA

Dust and Water resistance	IP54
Receiving Lens	14 mm
Focus	35 mm
Maximum Measuring Range	50 meters
Minimum Measuring Range	0.05 meters
Absolute Accuracy @ < 10m	± 1.5 mm (Max)
Repeatability Accuracy @ < 10m	± 1.5 mm (Max Typical, 2 σ)
Repeatability Accuracy @ > 10m	Increase ± 0.25 mm / meter (Max Typical, 2 σ)
Measurement Time	0.5 s
Display Type	LCD (22.7 mm x 31 mm)
Power Type	AAA 2x (Alkaline Battery)
Battery Life	10000 (Single Measure)
Laser Output Power	0.6 mW ~ 0.95 mW (Class 2, 650nm)
Laser Spot Size	25 mm x 30 mm @ 16 m(Max)
Laser Radiation Vertical Angle	±1 degree
Laser Radiation Horizontal Angle	±1 degree
Device auto off time	180 seconds
Laser auto off time	30 seconds
Operating Temperature Range	-10°C to +50°C
Storage Temperature Range	-25°C to +70°C
Weight without Battery	80 g

SPECIFIED CONDITIONS OF USE

The laser distance measurer can be used for measuring distances and tilts.
Do not use this product in any other way as stated for normal use.

ERROR CODE TABLE

Code	Description	Solution
Err01	Out of measuring range	Measure in a proper range
Err02	Reflect signal is too weak	Choose a better surface
Err03	Out of display range (max value: 99.999) e.g. result of area or volume is out of display range	Check and verify values and steps are correct
Err04	Pythagorean calculation error	Check and verify values and steps are correct
Err05	Battery is low	Install new batteries
Err06	Out of working temperature	Measure in an environment with the specified working temperature
Err07	Ambient light is too strong	Measure in a darker place (shadow target)

Single Pythagoras
Height difference

Measuring Reference

Normal Measuring Mode

Minimum / Maximum for continuous Measure

Addition / Subtraction

ON / MEASURE

- ▶ On
- ▶ Measure
- ▶ Continuous Measurement (push 2 sec)
+ Min / Max Function

ADD

- ▶ Add value
- ▶ Navigate in memory menu

AREAS / VOLUMES

- ▶ Area (push 1x)
- ▶ Volume (push 2x)
- ▶ Indirect Surface Measurement (push 3x / 4x)

POWER

- ▶ On
- ▶ Off (push 2 sec)
- ▶ Clear

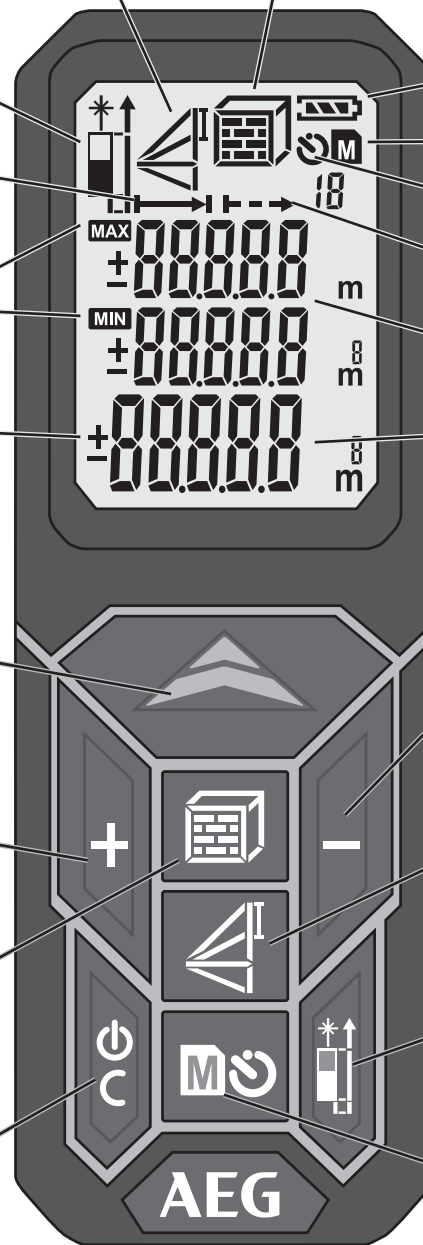

Area/ Volume
Indirect Surface Measurement

Battery Status

Memory

Timer

Continuous measure mode

Among Values

Main Value

SUBTRACT

- ▶ Subtract value
- ▶ Navigate in memory menu

PYTHAGORAS

- ▶ Pythagoras 1 (push 1x)
- ▶ Pythagoras 2 (push 2x)
- ▶ Pythagoras 3 (push 3x)

CHANGE POINT OF MEASURE

- ▶ Front
- ▶ Back (Standard automatical)
- ▶ Corner pin

MEMORY

- ▶ Timer 3-15 sec (push 1x)
- ▶ Memory 1-20 (push 1x, 2 sec)
- ▶ Use +/- to navigate the measures in memory

CHANGE BATTERIES

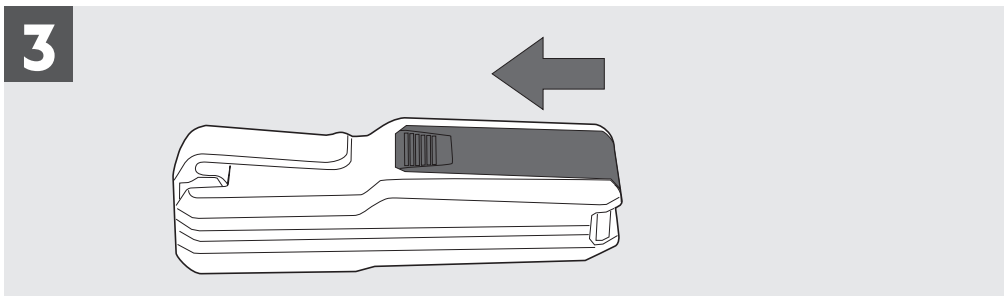
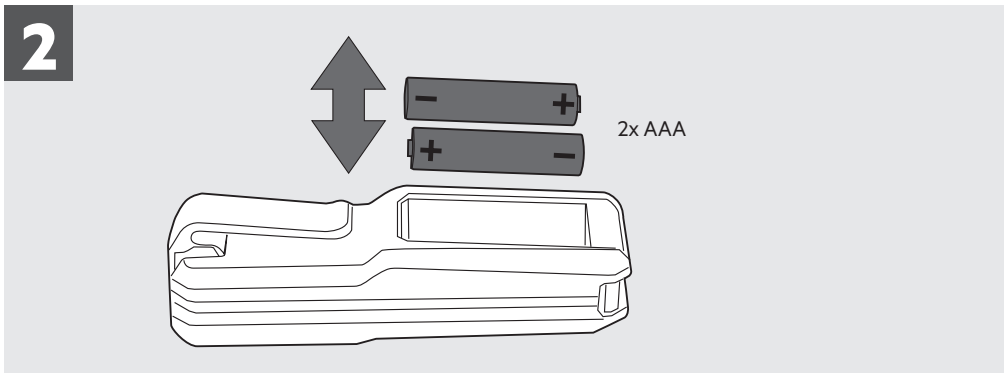
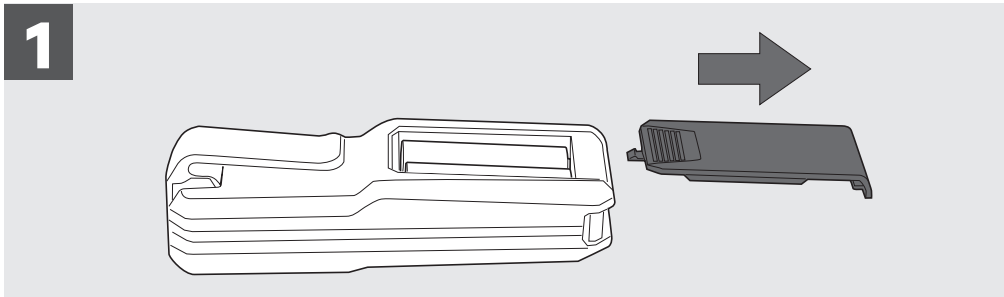
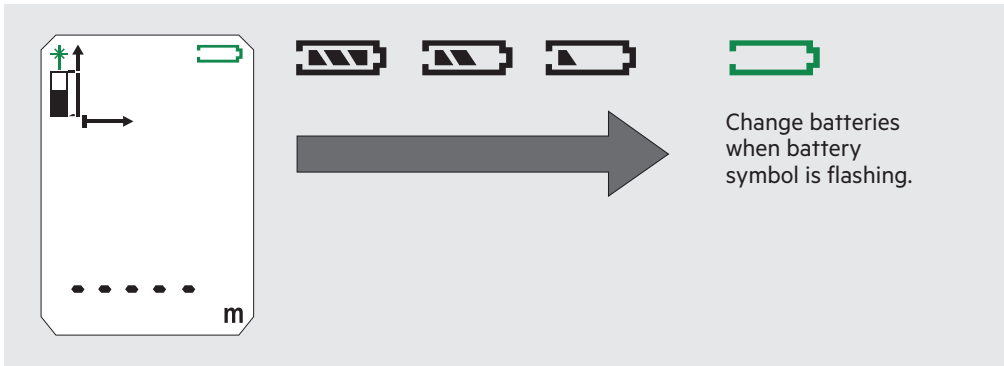

CORNER PIN

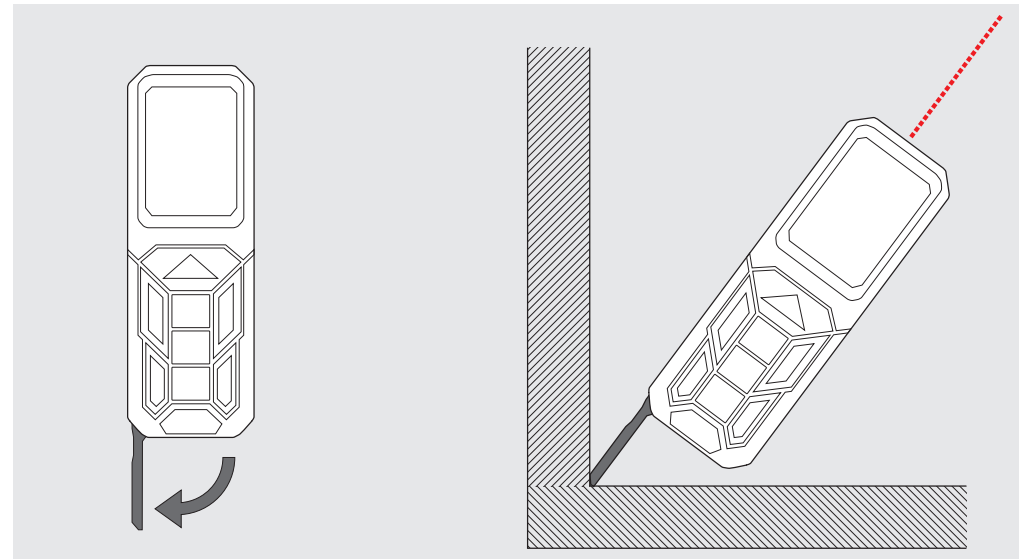

BELT CLIP

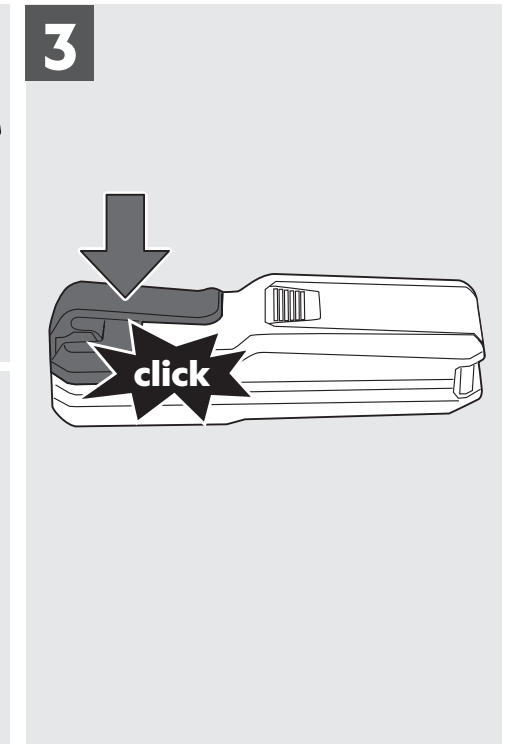
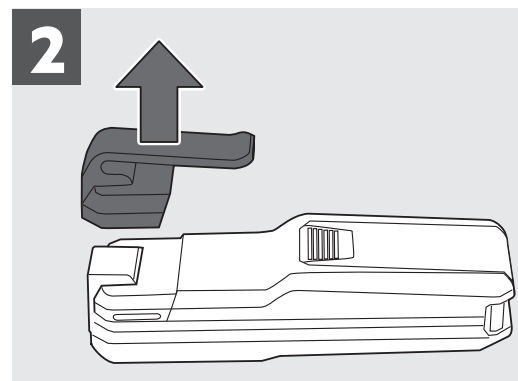
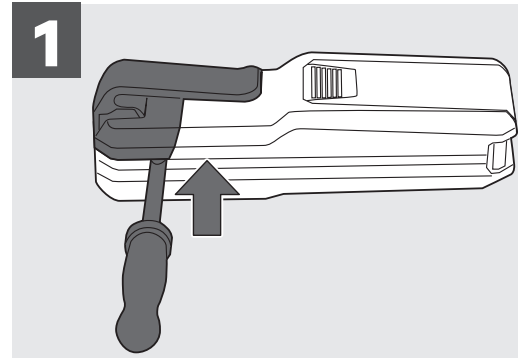

FUNCTION SWITCH, PYTHAGORAS, MEASURING REFERENCE

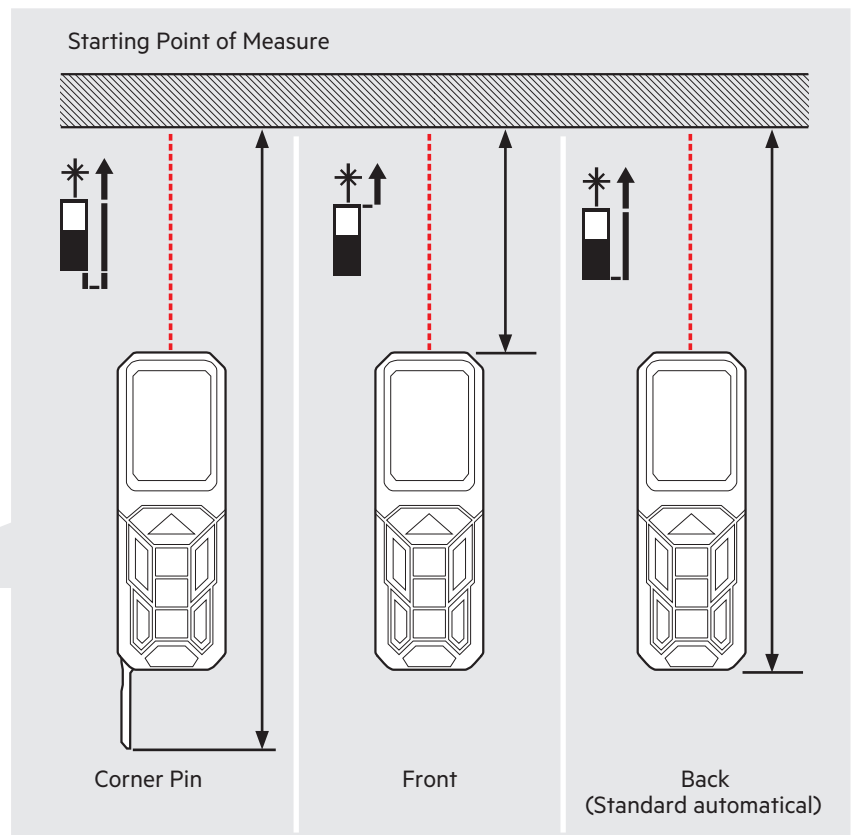
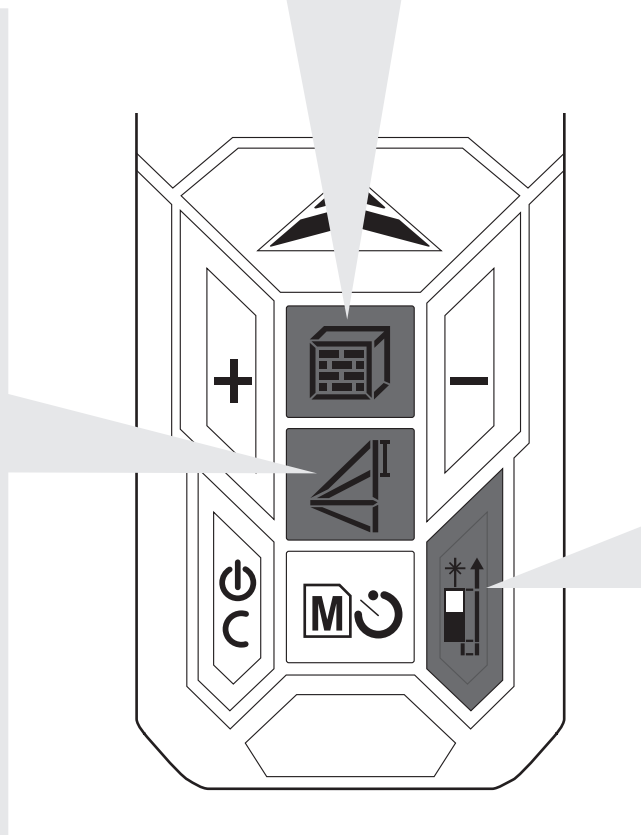
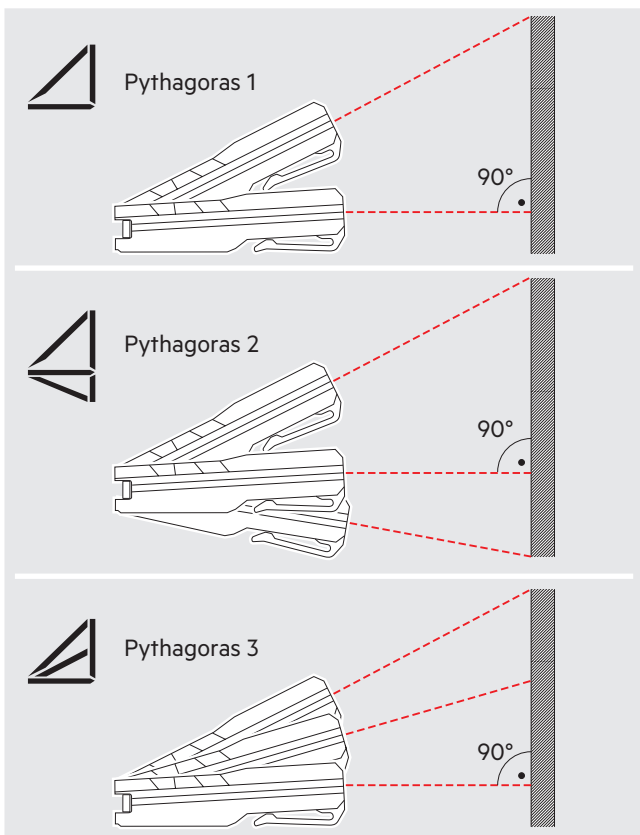
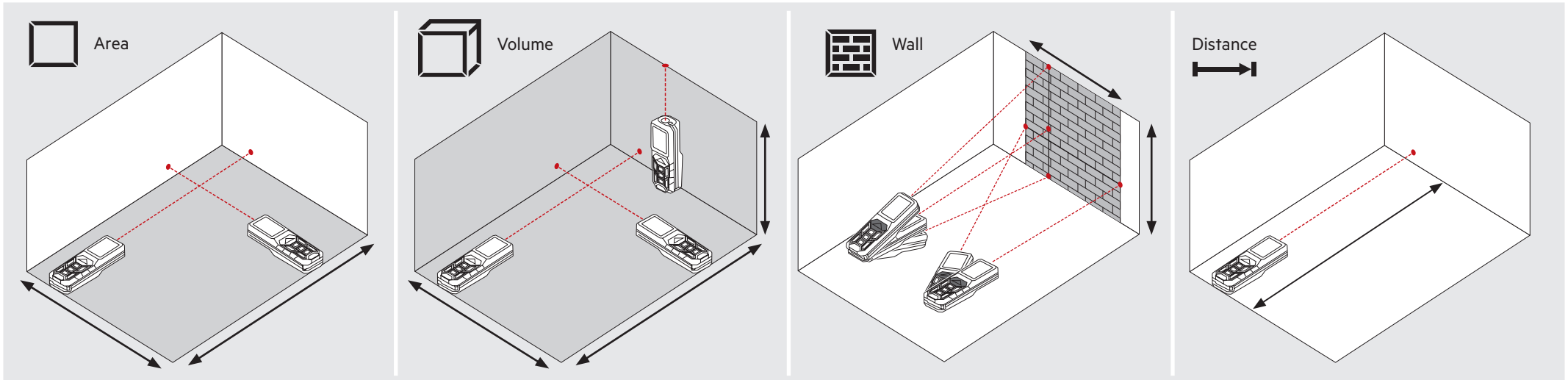

SINGLE DISTANCE MEASURING

0

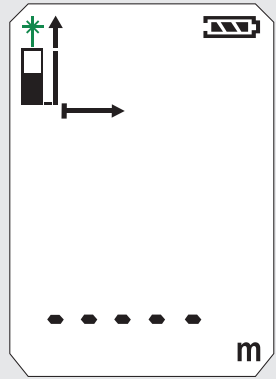

1

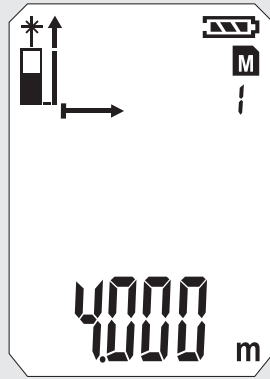
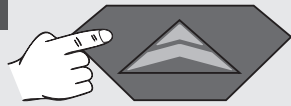

2

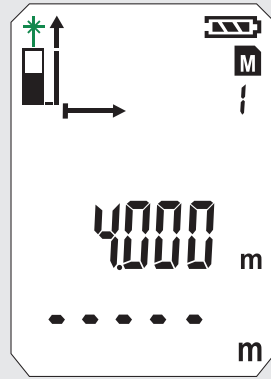
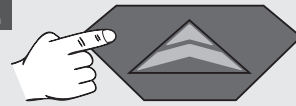

3

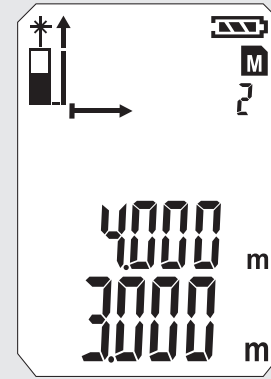
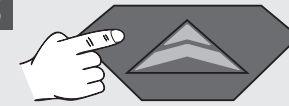

4

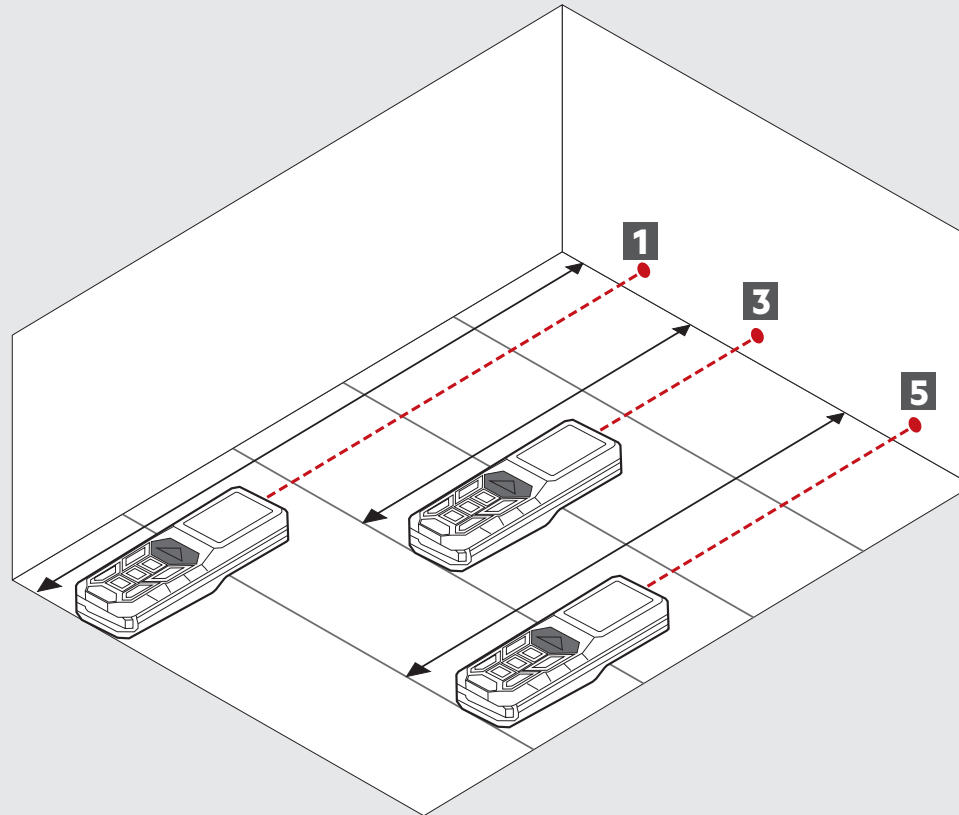
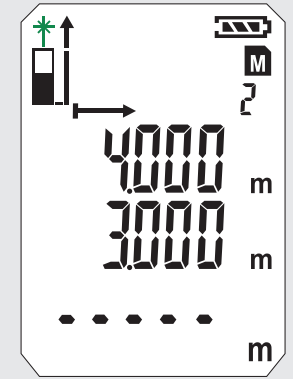
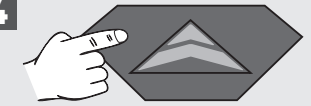

5

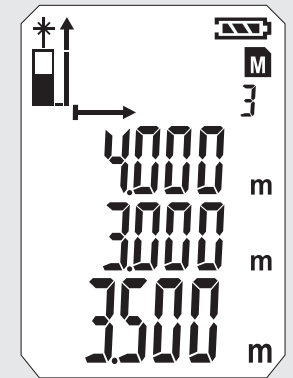
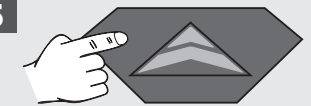

PERMANENT / MINIMUM-MAXIMUM MEASURING

0

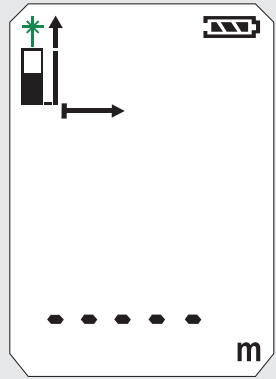

1

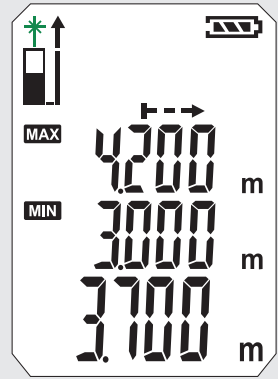
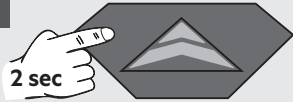

2

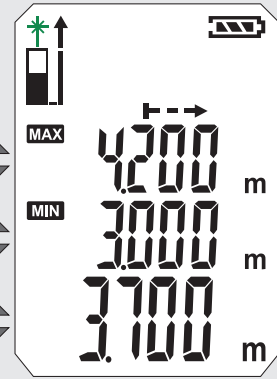
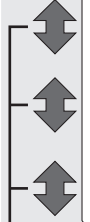

3

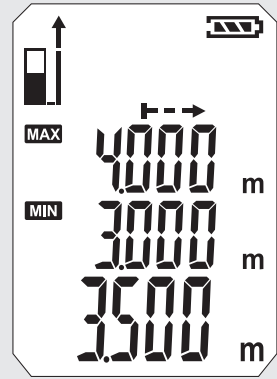
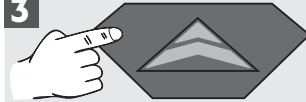

4

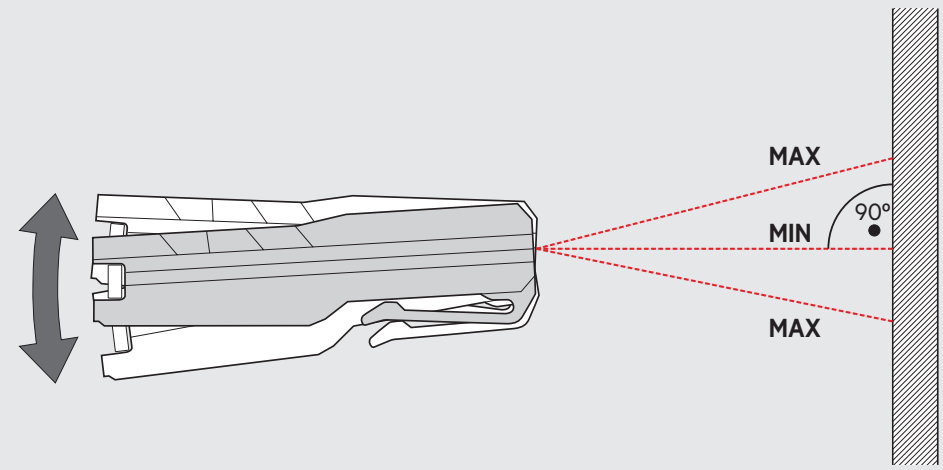
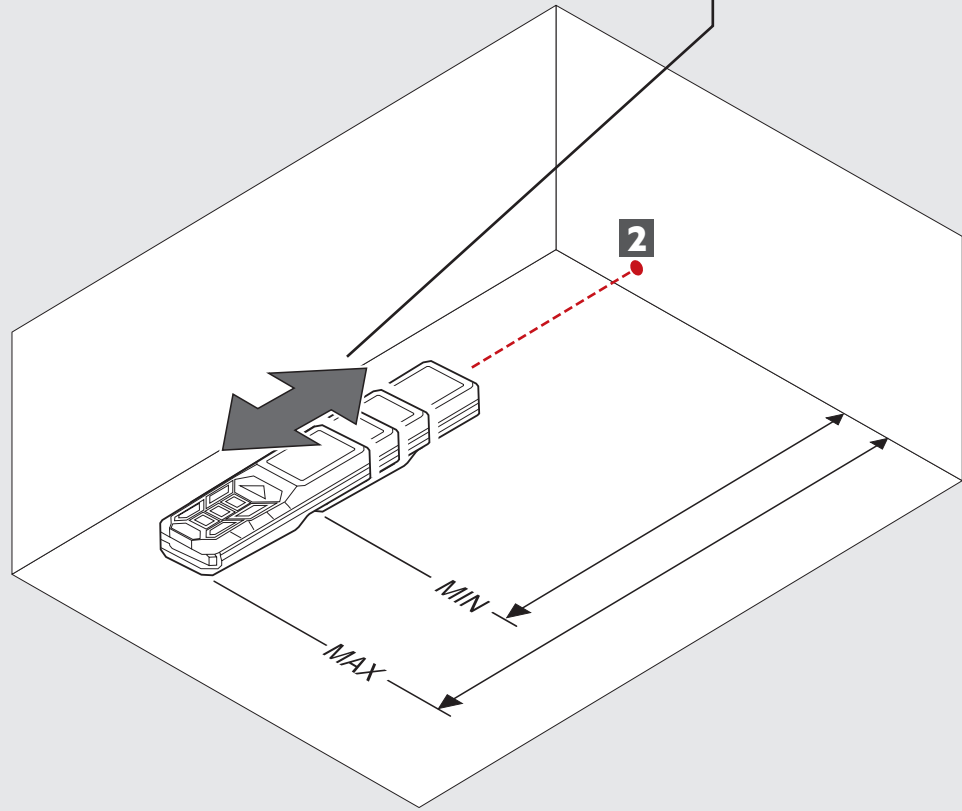
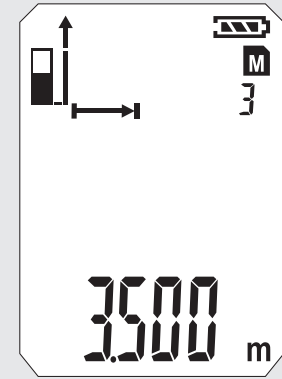

0

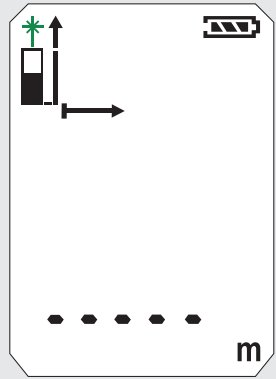

1

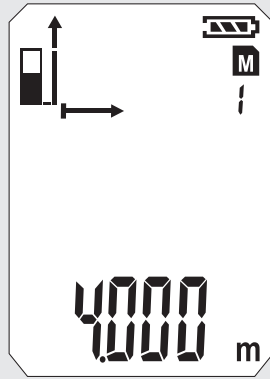
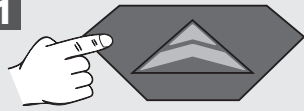

2

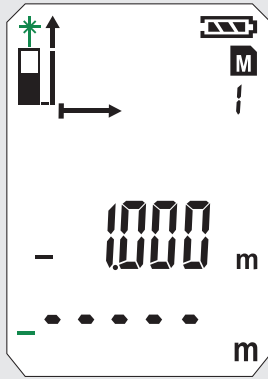
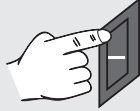

3

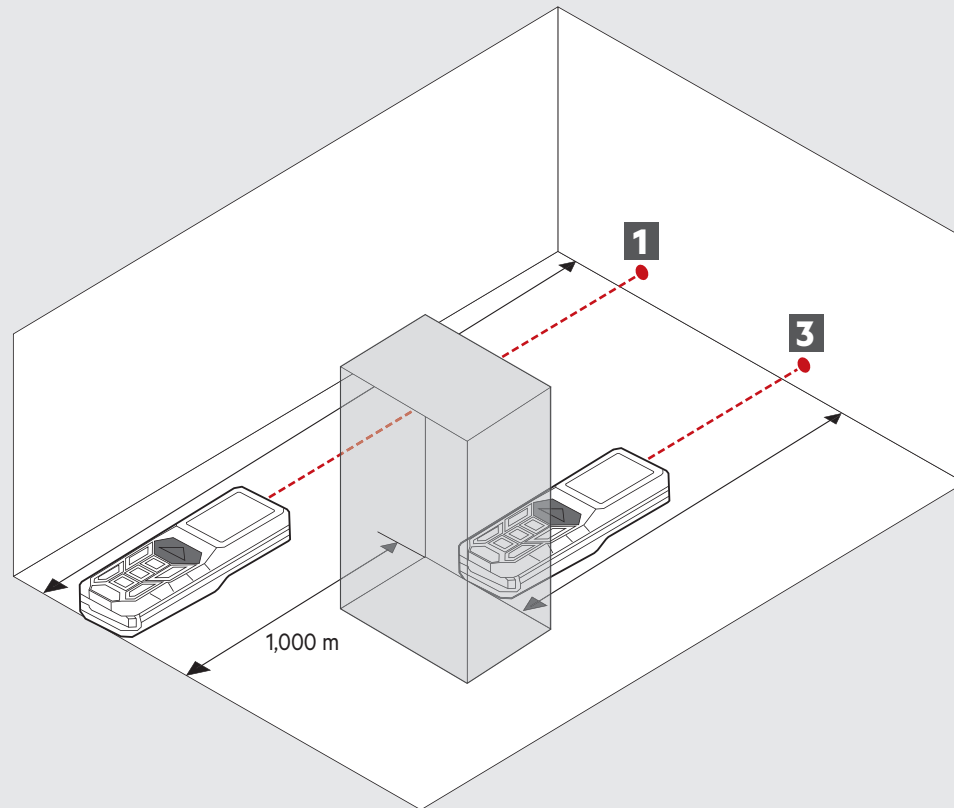
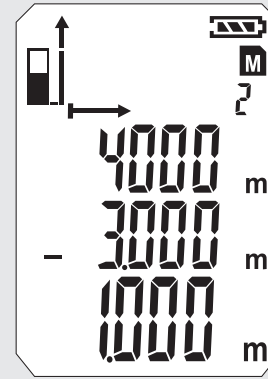
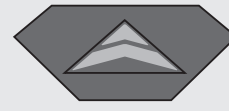

AREA MEASURING

0



1

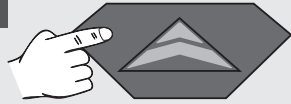

2

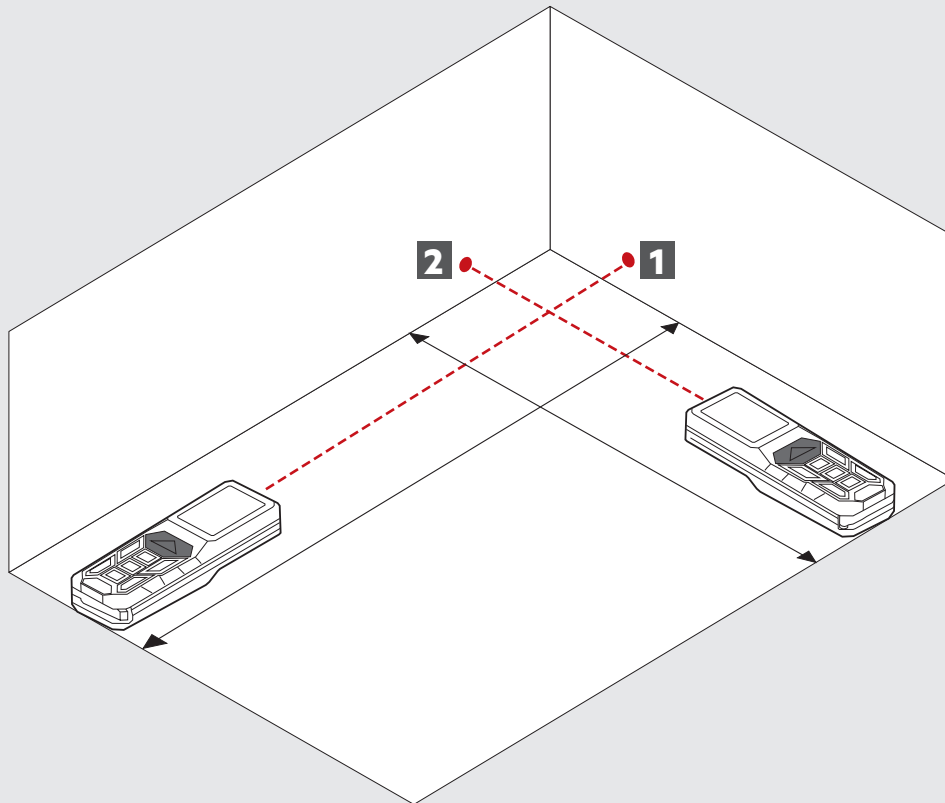
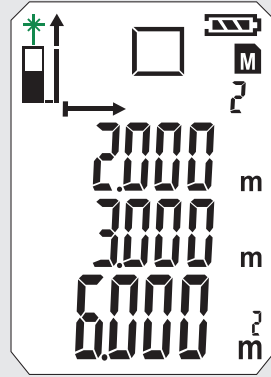
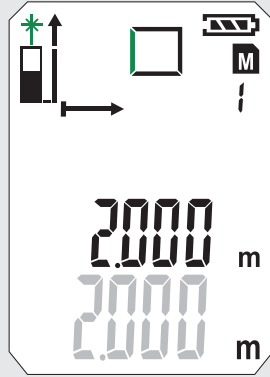
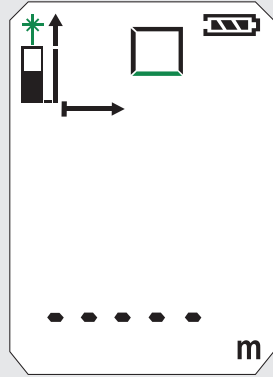
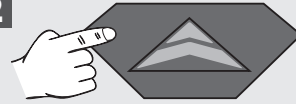

VOLUME MEASURING

0



1

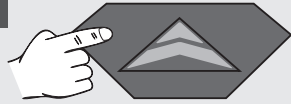

2

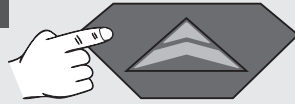

3

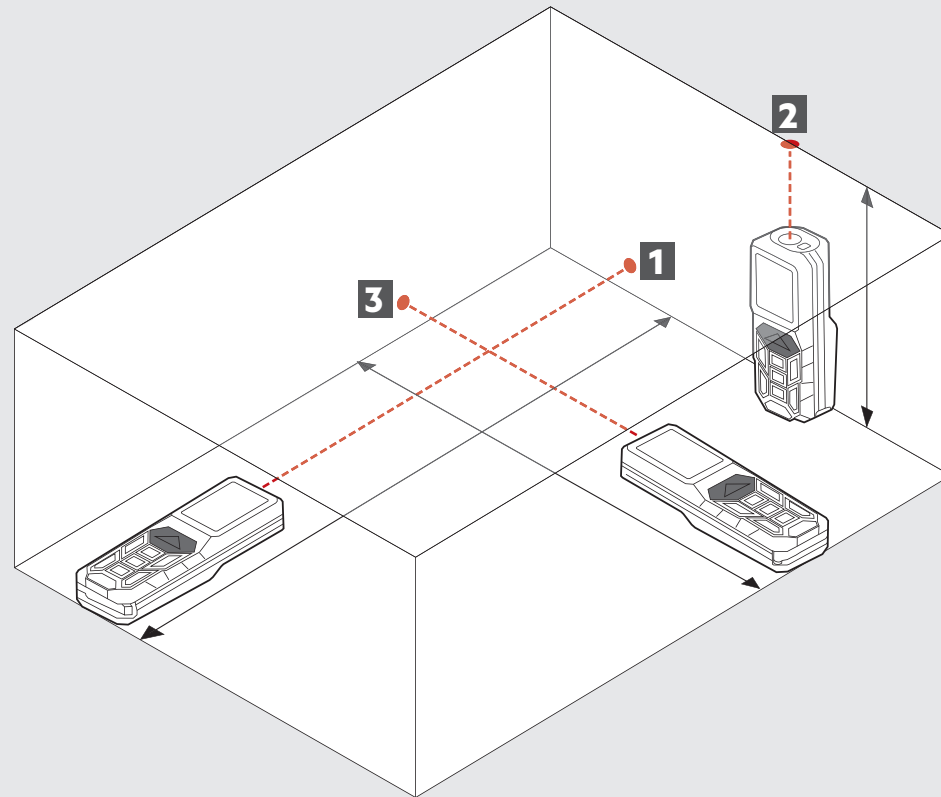
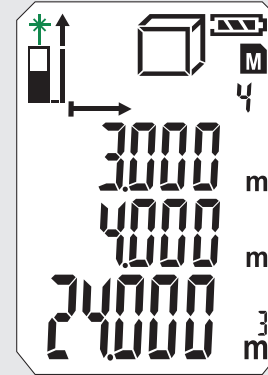
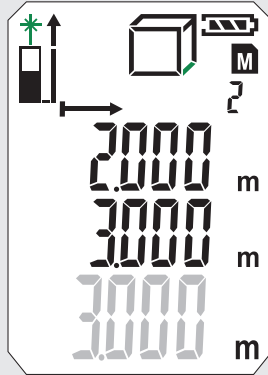
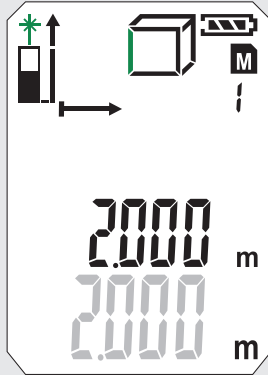
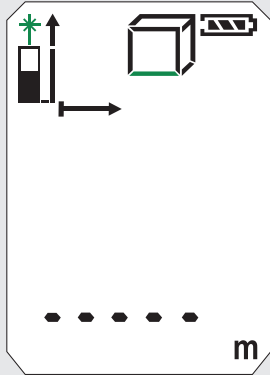
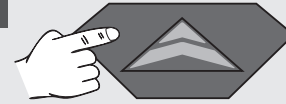

INDIRECT MEASURING (PYTHAGORAS 1)

0



1

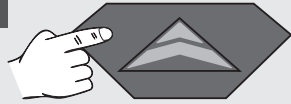

2

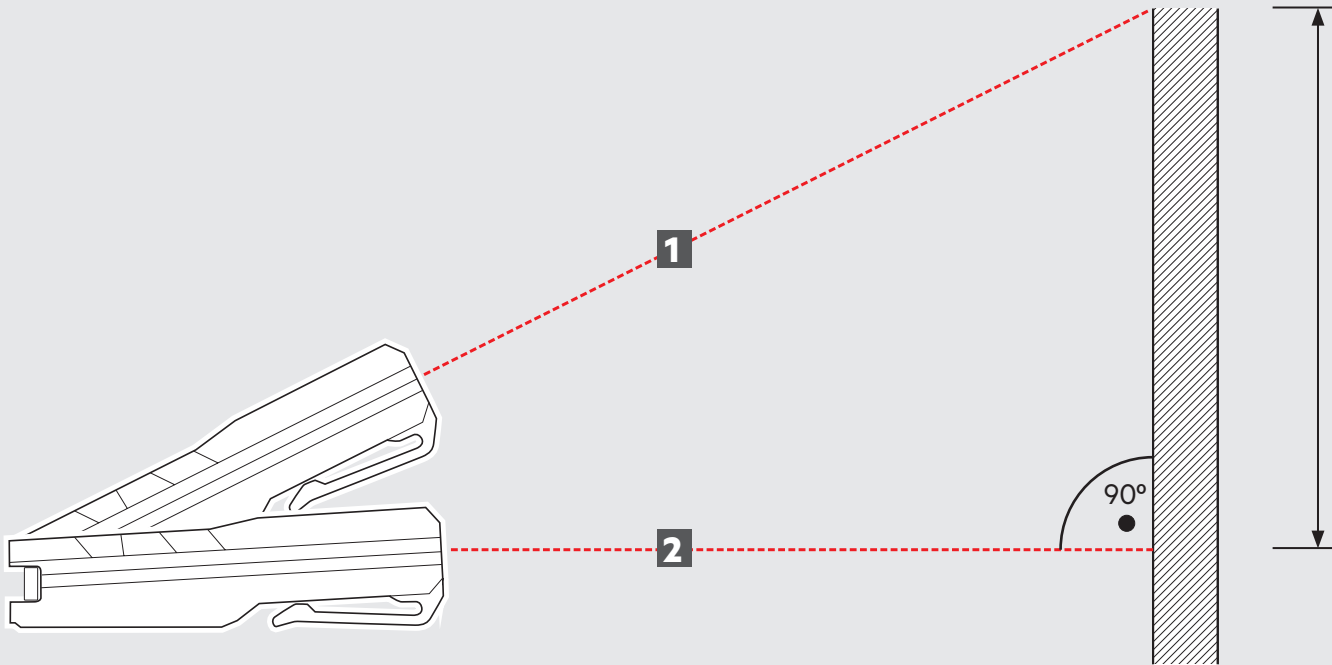
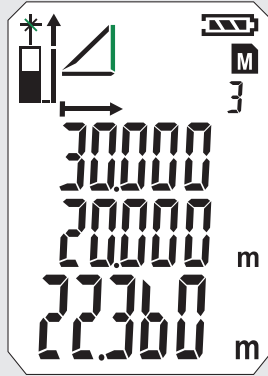
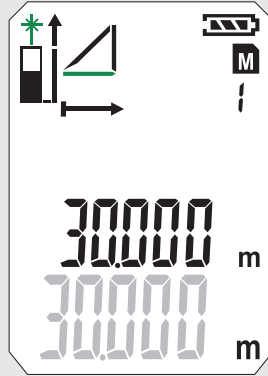
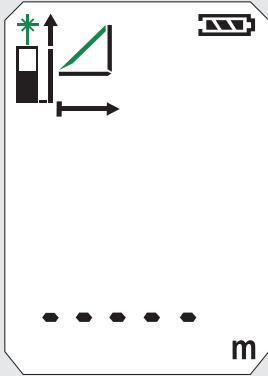
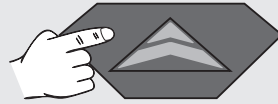

INDIRECT MEASURING (PYTHAGORAS 2)

0



1

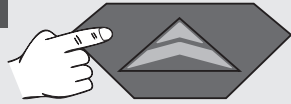

2

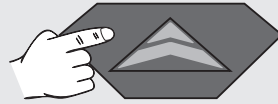

3

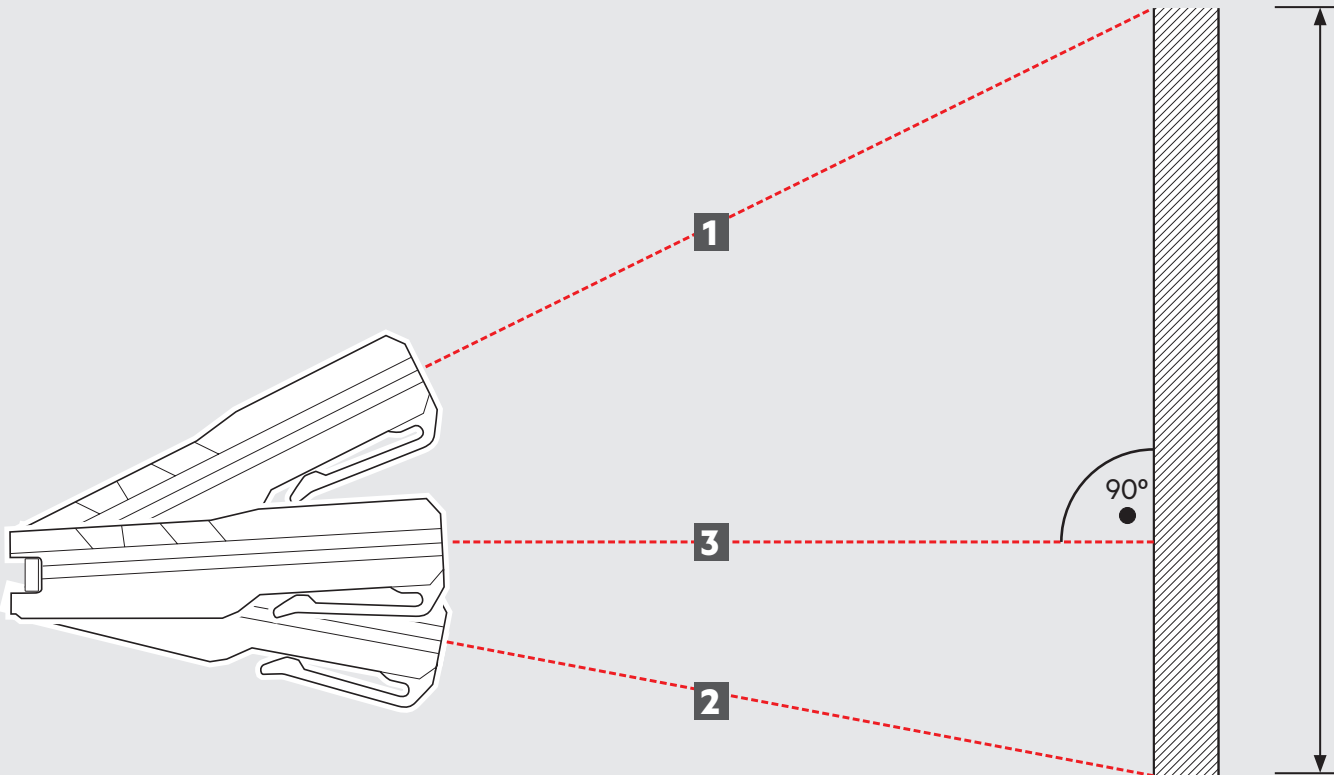
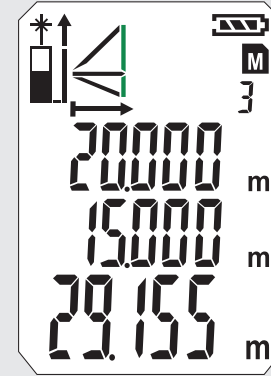
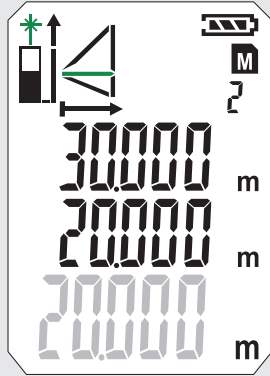
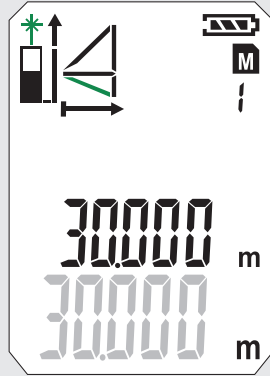
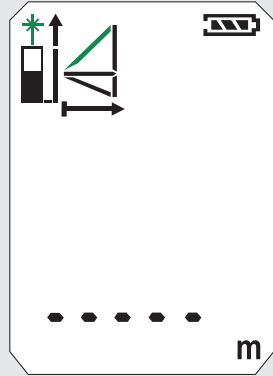
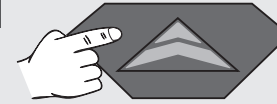

INDIRECT MEASURING (PYTHAGORAS 3)

1



2

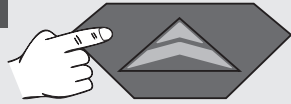

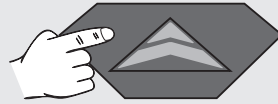

3

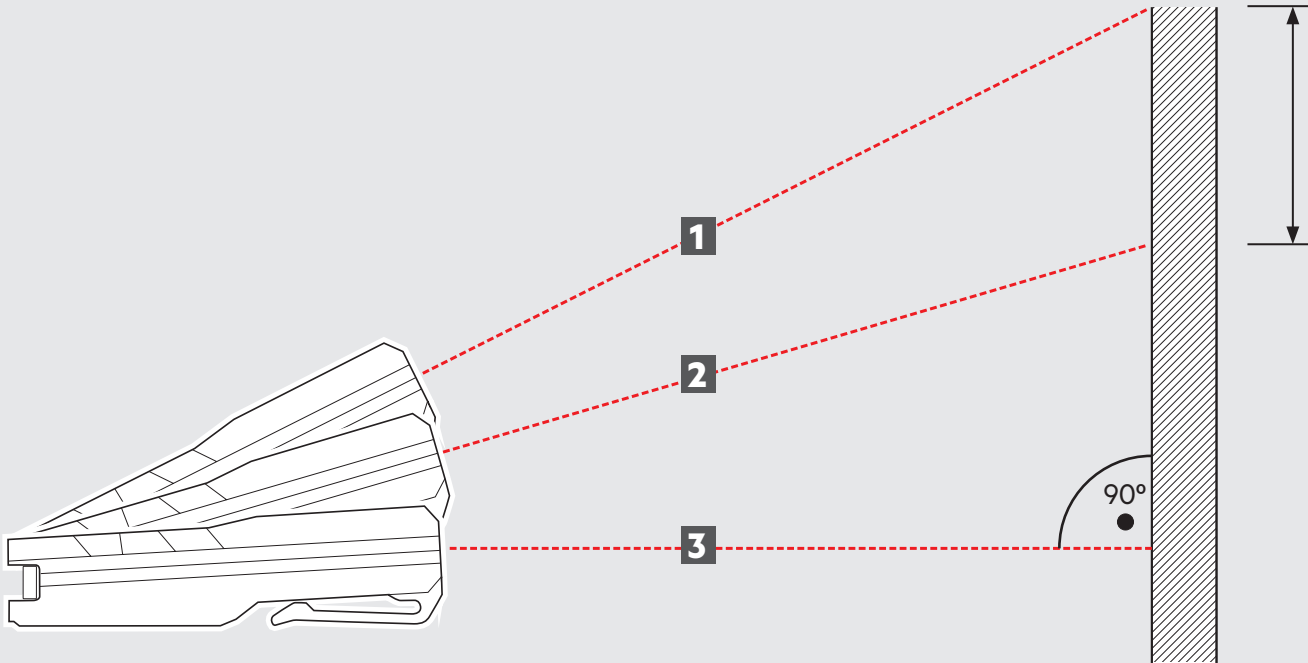
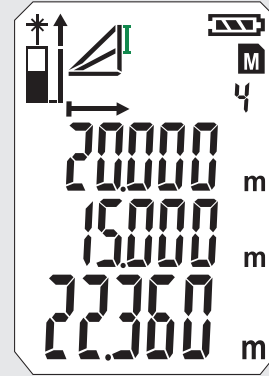
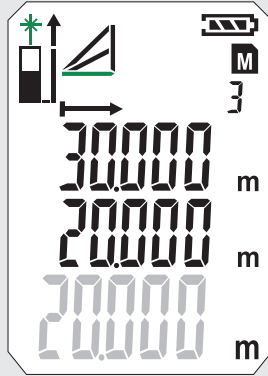
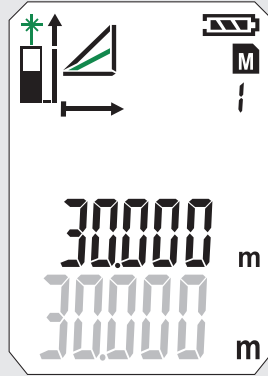
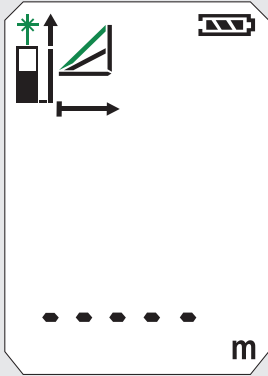
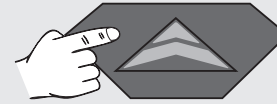

4

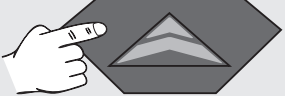
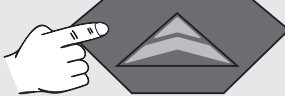
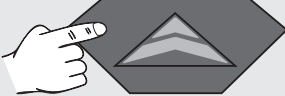
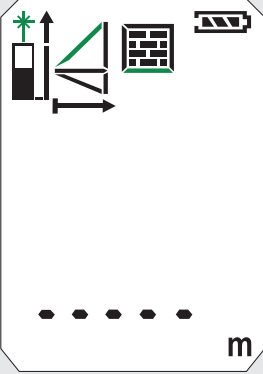
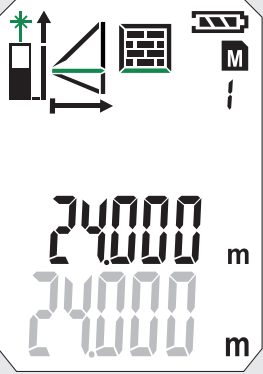
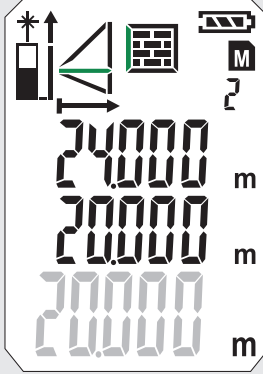
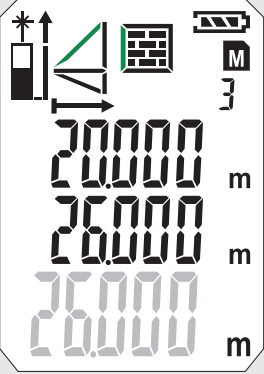
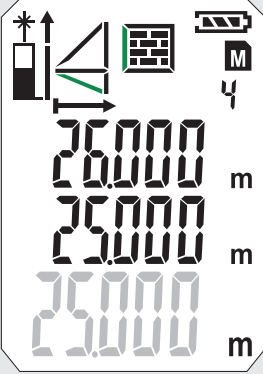

WALL AREA MEASURING (SCENARIO 1)

<p>0</p> 	<p>1</p> 	<p>2</p> 	<p>3</p> 	<p>4</p> 
				

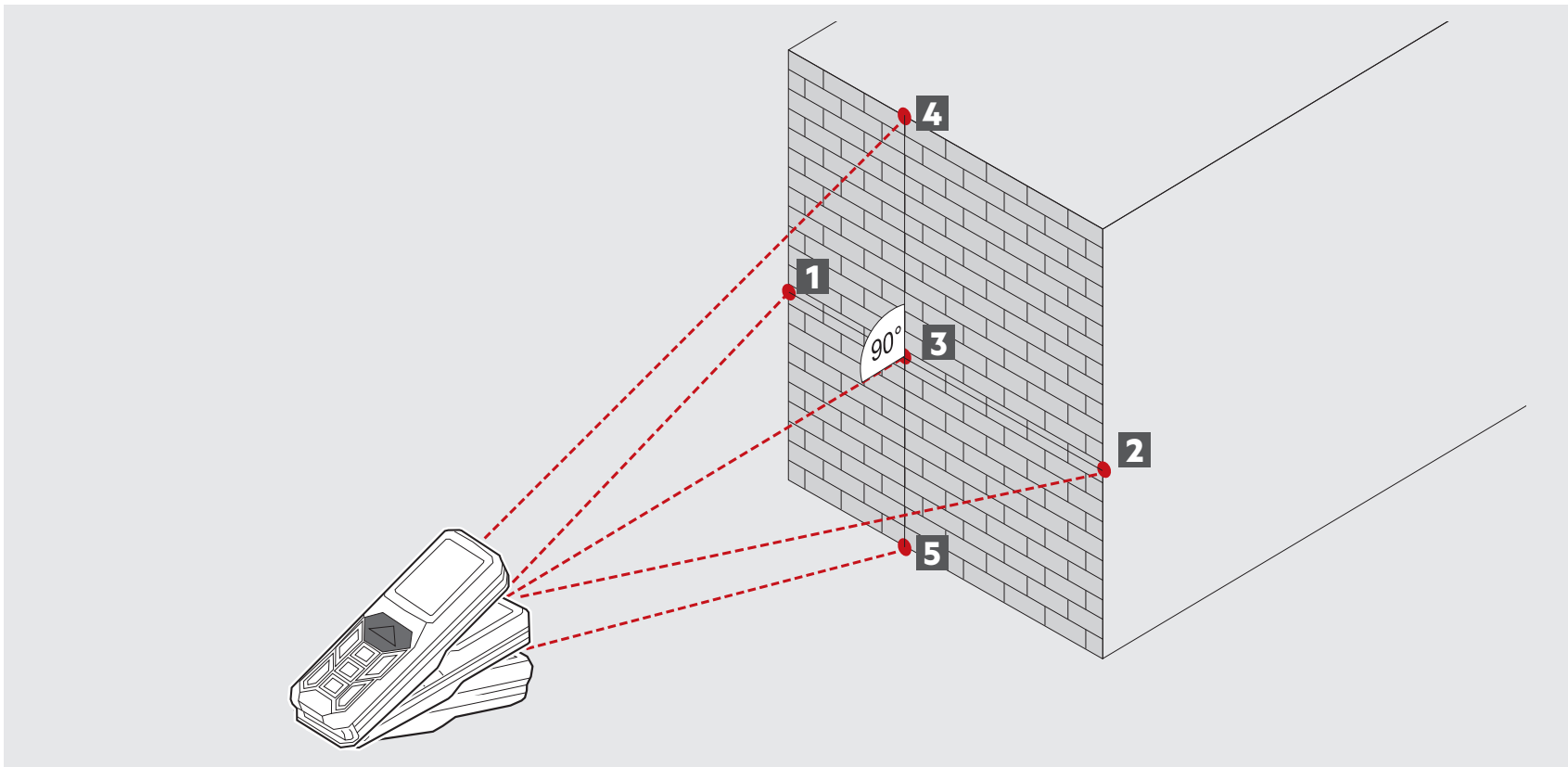



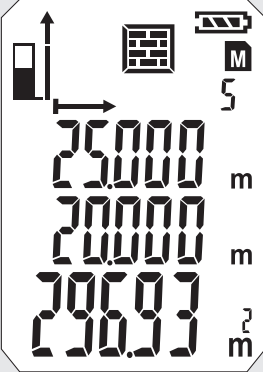

5



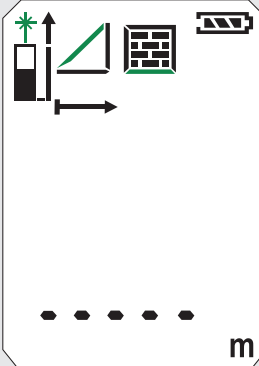
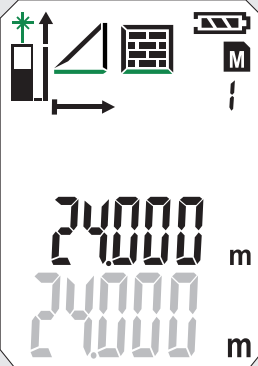
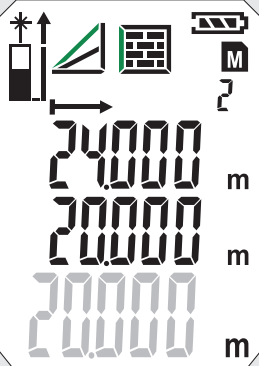
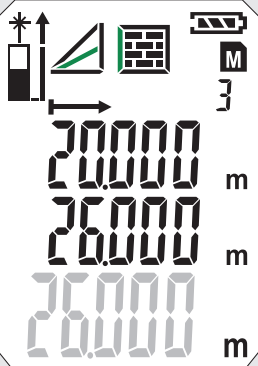
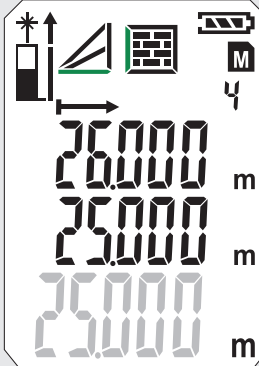

WALL AREA MEASURING (SCENARIO 2)

<p>0</p> 	<p>1</p> 	<p>2</p> 	<p>3</p> 	<p>4</p> 
				

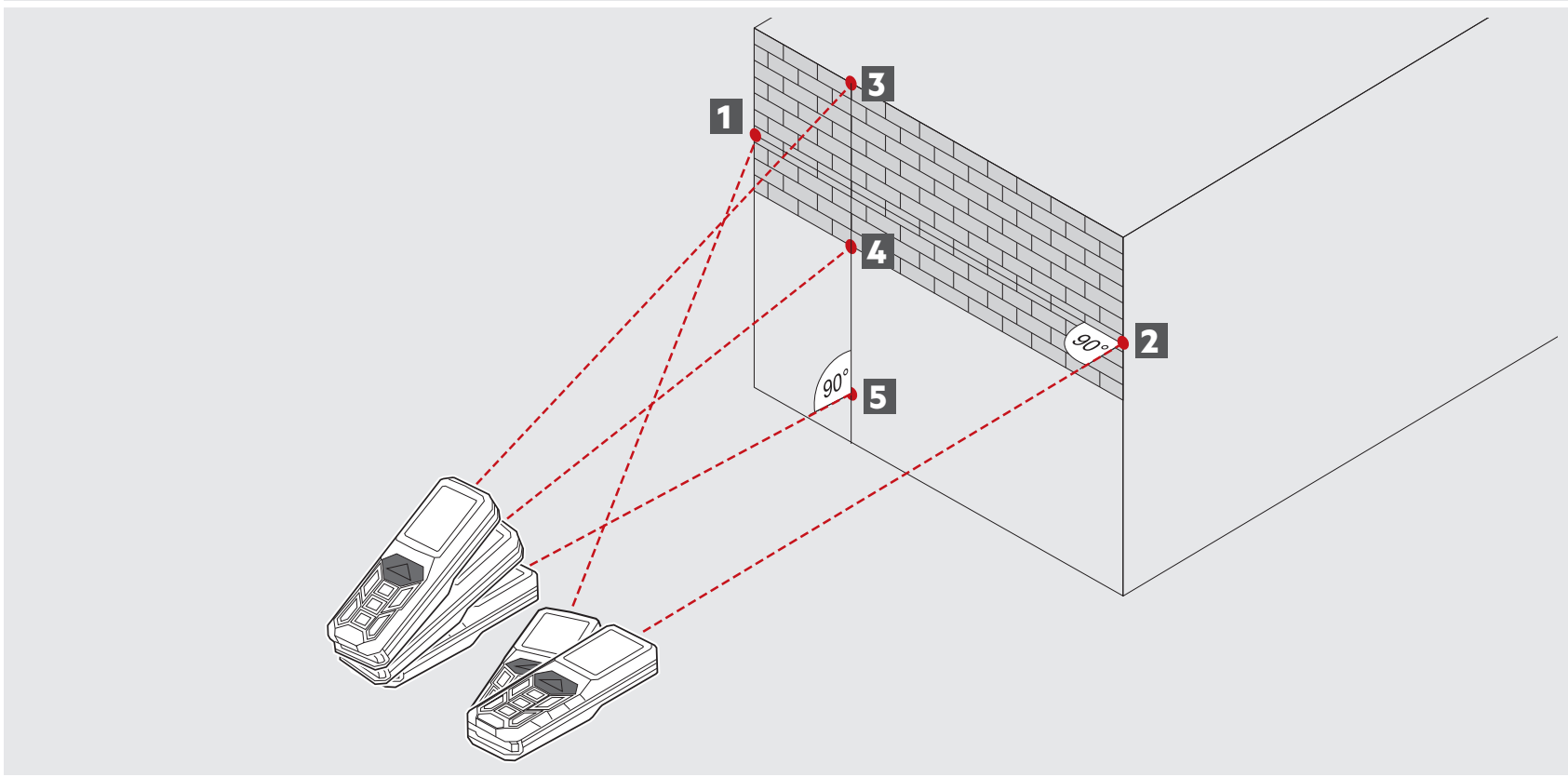

5



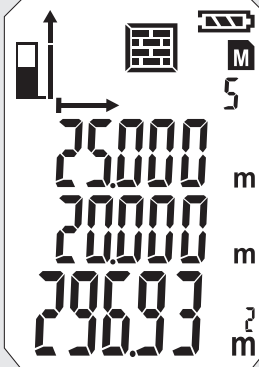



TIMER

With the timer, the measurement can be start delayed. For example to position a part in the measuring beam.

Push button 

- Icon is displayed.
- Timer can be set between 3 to 15 sec by pressing the button .

Push button 

- The seconds are counted down until the measurement starts.
- At 0, the measurement starts.

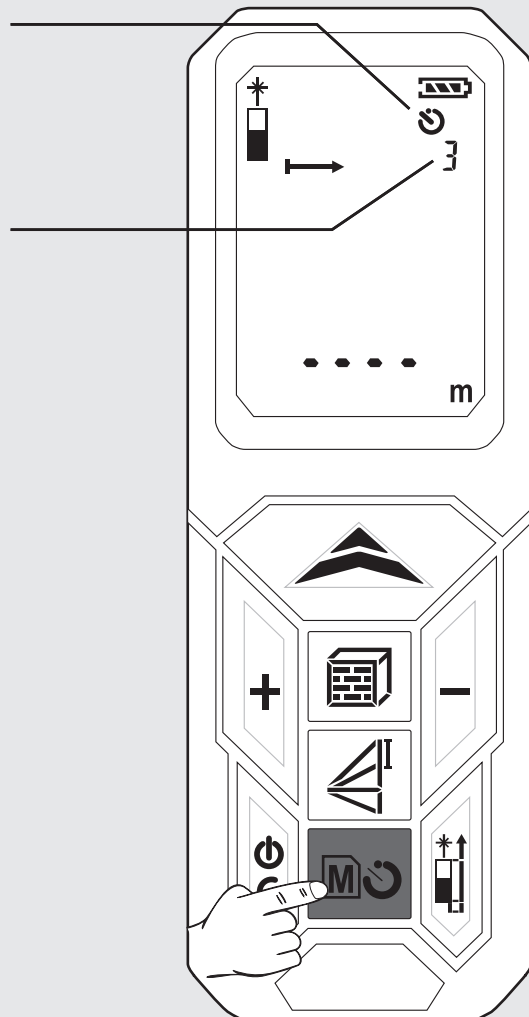

MEMORY

The measured values are stored continuously and automatically in memory.

The stored values can be retrieved by pushing the button .

Push the button  2 sec.

- Icon and memory number appears.
- associated measured parameter is shown.
- Stored value is displayed in the main line.
- Navigate with the + / - buttons

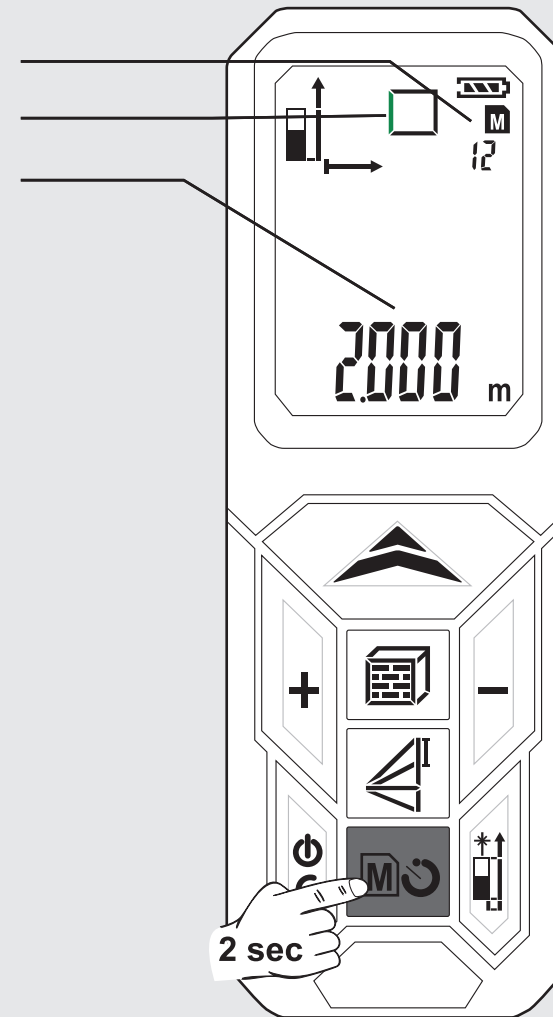



BASIC DESCRIPTION ON EXAMPLE OF AREA MEASURING (1)

1 Turn On

Push Button 
⚠ Attention! Laser on!
 Do not point it at a person!

Laser icon flashes
 (flashing green illustrated)

2 Choose Measuring Reference

Standard after turning on: Bottom
 Push 1x -> Corner Pin
 Push 2x -> Top
 Push 3x -> Bottom

Icon is displayed.

3 Choose Function

After switching on the device is
 always on single distance
 measurement
 Push 1x - Area Measurement.

- Icon appears.
 - Measured parameter flashes
 (flashing green illustrated)

4 Measure length

Level the device
 and push
 button 

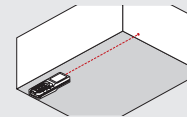

- Measured value appears briefly in
 the main line.
 - Measured value jumps by 1 sec in
 line above.
 - Measured value is stored in
 memory at consecutive numbers.
 - Second measured parameter
 flashes.
 Device ready for measurement of
 the second value.

5 Measure width

Level the device
 and push
 button 

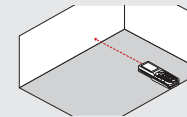

- Measured value appears briefly in
 the base line.
 - Measured value jumps by 1 sec in
 line above.
 - Measured value is stored in
 memory at consecutive numbers.
 - Result is displayed in the main line
 and stored in memory at
 consecutive numbers.

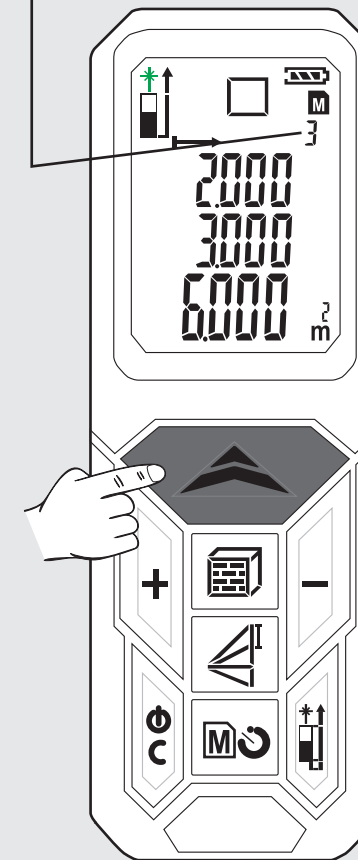
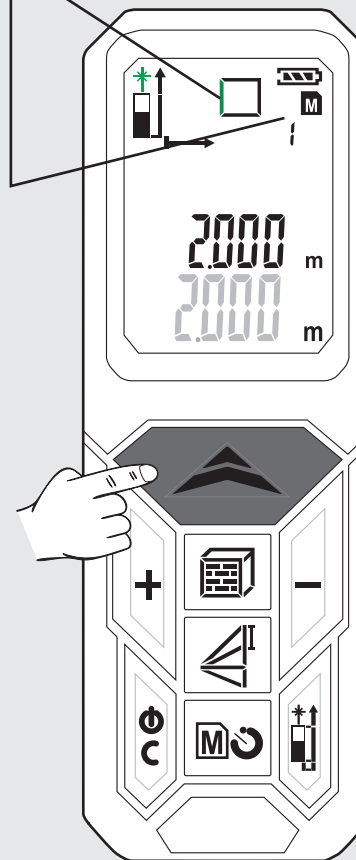
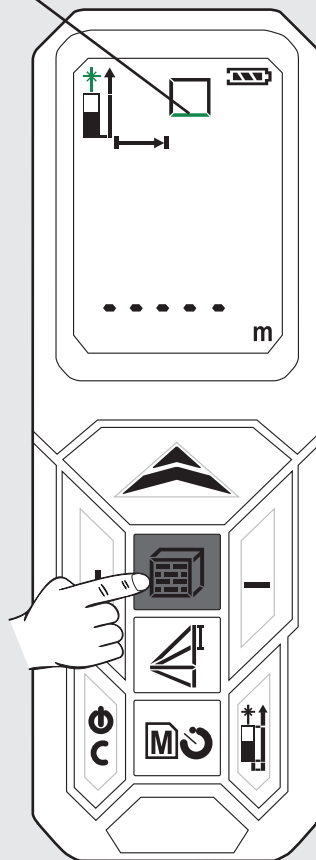
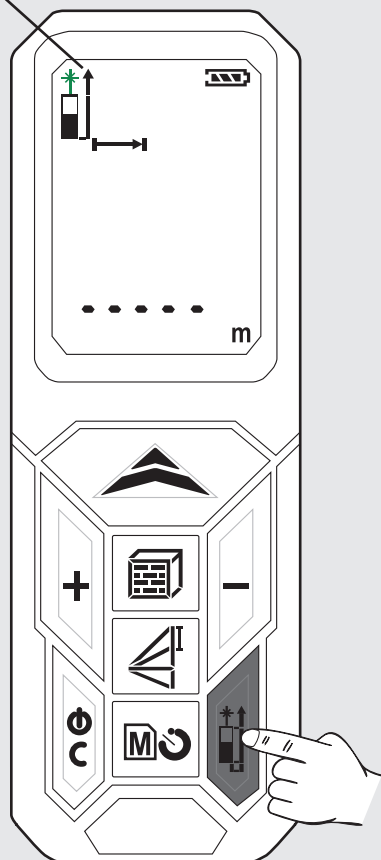
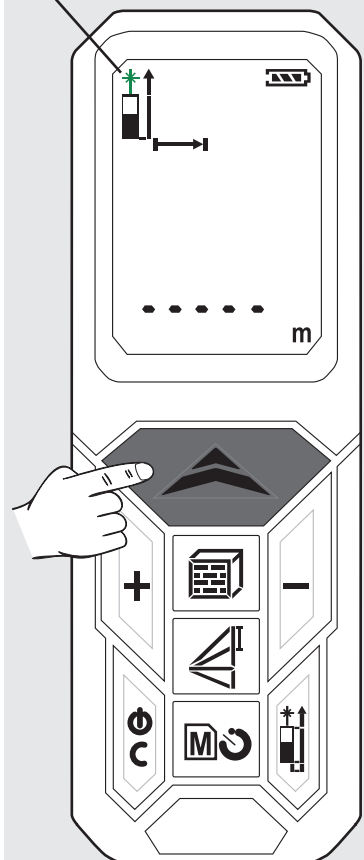

BASIC DESCRIPTION ON EXAMPLE OF AREA MEASURING (2)

6 View stored values

Push button  2 sec.
Push + or push -

7 Exit memory

Push button .

8 Switch off

Push button  2 sec.
(Memory must be exited before)

- Stored values appears in the main line.

- Associated icon appears and measured parameter flashes (flashing green illustrated)

- Device switches off.

- If no button is pressed, the device switches off automatically after 3 minutes.

