

12-14 HEX HEAD SDM TOPGRIP

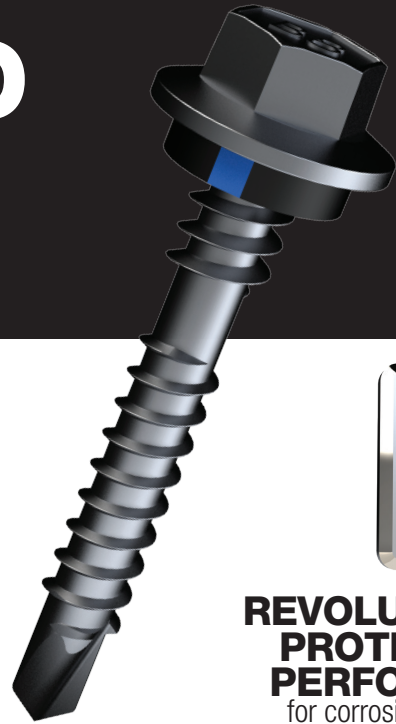

**REVOLUTIONARY
PROTECTION &
PERFORMANCE**
for corrosive environments

APPLICATION

Bremick® 12-14 Hex Head SDM TopGrip Screw is used for crest fixing roof sheets to steel purlins.

Available with EDPM Sealing Washer only.

PRODUCT ATTRIBUTES



B8 Hex Drive provides traceability and offers greater engagement and hex socket stability.

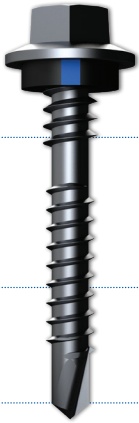

Top grip provides a positive seal and reduces the roof sheet riding down.

Finish High Corrosion performance with the B8® Coating. Suitable for Category 5 corrosive environments in accordance with ISO 9223-2012 and AS4312-2019.

SDM Point for into steel while ensuring maximum pullout strength and a high strip torque.

DRILLING & INSTALLATION CAPACITY

Base Materials:

- Metal Battens G550
- Steel Purlins G450

Max drilling capacity of 5.0mm.

When fastening metal, ensure 3 threads minimum embedment, protrude below battens / purlins.

INSTALLATION INSTRUCTIONS

1. Use a 5/16" Bremick® Hex Socket.
2. Insert the socket into a Power tool and select a drive speed of 1000 to 1500 RPM.
3. Fit the screw into the socket and position the screw point on the crest of the Rib.
4. Commence drilling at "slow speed" to pierce sheeting.
5. Apply firm pressure, drive until the seal seats firmly. Do NOT overdrive. Reverse screw if washer or roof sheet is deformed from over driving.

12-14 HEX HEAD SDM TOPGRIP

MECHANICAL PROPERTIES

SIZE	Single Shear (kN)	Axial Tensile (kN)	Torsional (Nm)
12-14	8.4	14.4	13.1

PULL OUT VALUES

Mean Ultimate Pull Out Force kN – Steel Purlins

SIZE	1.0mm BMT G450	1.2mm BMT G450	1.5mm BMT G450	1.9mm BMT G450	2.4mm BMT G450	3.0mm BMT G300	4.0mm BMT G300
12-14	2.8	3.2	4.0	5.5	5.8	7.6	9.7

Mean Ultimate Pull Out Force kN – Metal Battens

SIZE	0.42mm BMT G550	0.55mm BMT G450	0.55mm BMT G550	0.75mm BMT G550	0.9mm BMT G550	1.0mm BMT G550	1.2mm BMT G550
12-14	0.9	0.9	1.0	1.7	2.0	2.1	2.6

Note: The above data represents characteristic capabilities obtained under laboratory conditions and are only applicable to Bremick products. The design professional must apply appropriate safety factors.

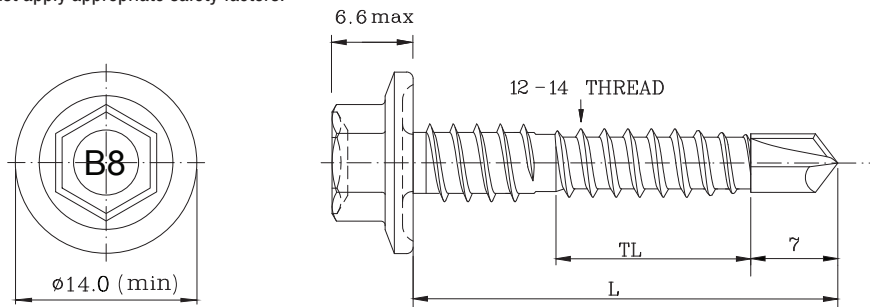

RANGE

Product Code	Description	Head Driver	Pack Qty (EA)	Finish	Length L (mm)	Thread Length TL (mm)
SMHT8120351	TG SDM 12-14x39 HEX +SL	5/16" Hex	1000	B8® COATING	39	19
SMHT8120357	TG SDM 12-14x39 HEX +SL	5/16" Hex	100	B8® COATING	39	19
SMHEXT8120391T	TG SDM 12-14x39 HEX +SL	5/16" Hex	100	B8® COATING	39	19

Whilst every care was taken in the preparation of this publication, Bremick® accepts no responsibility for the accuracy of the information supplied. Bremick® reserves the right to make alterations to specifications as part of ongoing development and improvement. This publication serves as a guide and it's the responsibility of the end user to ensure suitability for their application.

The contents of this publication are the exclusive copyright of Bremick® and may not be reproduced without permission.

BREMICK®

Bremick Pty Ltd

Head Office | 88 Dalmeny Avenue, Rosebery 2018
National Distribution Centre | M5/M7 Logistics Park,
Warehouse 4B, 290 Kurrajong Road, Prestons NSW 2170

www.bremick.com.au